

# Worksheet

12/06/2020

Free on dw-math.com

Problem quickname: 2200

1)

State the formulas for the required metrics of the given shape and calculate their approximate values.

a)

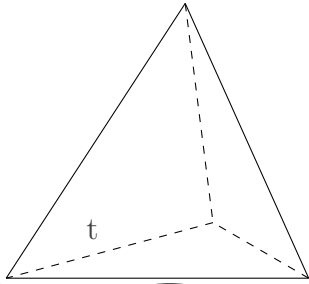

All edges are of the same length with  $t = 8$ . What is the volume and surface area of this shape? Round to the nearest whole number.

b)

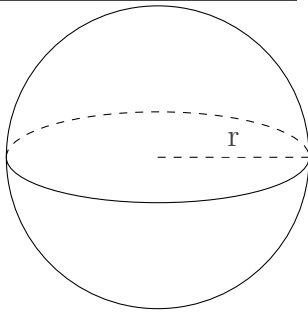

We have  $r = 14$ . What is the volume and surface area of this shape? Round to the nearest whole number. Assume the value of 3.14 for pi.

c)

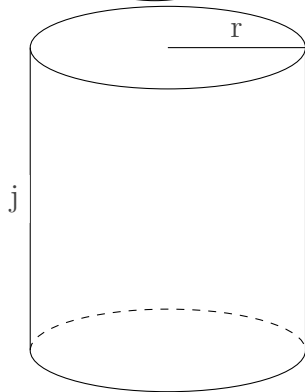

The base of this shape is formed by a circle. We have  $r = 5$ ,  $j = 11$ . What is the volume and surface area of this shape? Round to the nearest whole number. Assume the value of 3.14 for pi.

d)

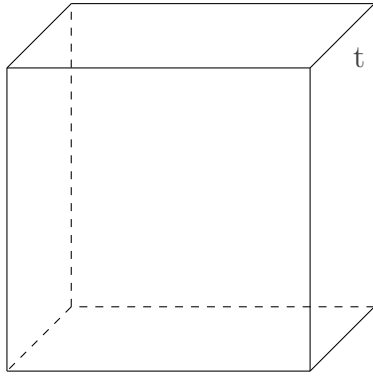

All edges of the shape are of the same length with  $t = 19$ . What is the volume and surface area of this shape?

2)

State the formulas for the required metrics of the given shape and calculate their approximate values.

a)

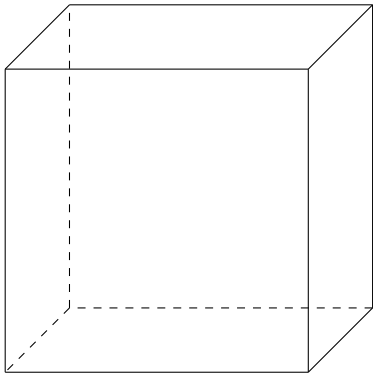

This is a cube. All edges of the shape are of the same length with  $a=24$  cm. What is the volume and surface area of this shape?

b)

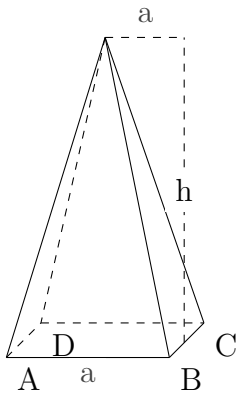

This is a square pyramid. The base of this shape is formed by a square. We have  $a=7$  cm,  $h=13$  cm. What is the volume and surface area of this shape?

c)

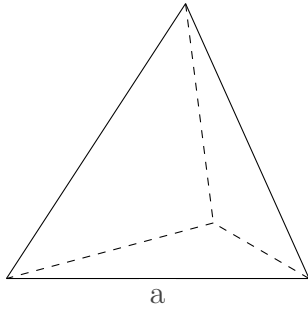

This is a regular tetrahedron. All edges are of the same length with  $a=6$  mm. What is the volume and surface area of this shape? Round to the nearest whole number.

d)

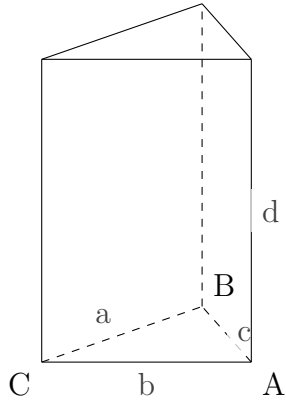

This is a prism. The base of this shape is formed by a triangle ABC which has an area of  $A(\text{triangle})=486$   $\text{cm}^2$ . We have  $a=27$  cm,  $b=36$  cm,  $c=45$  cm,  $d=52$  cm. What is the volume and surface area of this shape?

3)

State the formulas for the required metrics of the given shape.

a)

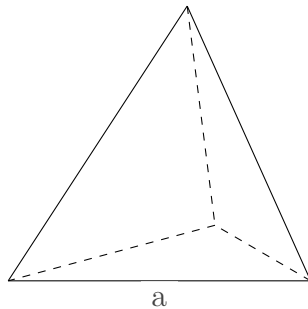

This is a regular tetrahedron. All edges are of the same length with  $a=20$  m. What is the volume of this shape?

b)

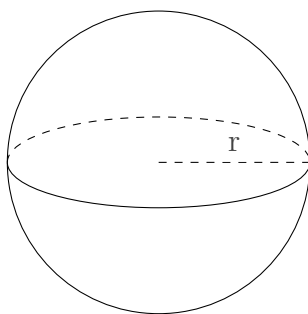

This is a sphere. We have  $r=3$  m. What is the surface area of this shape?

c)

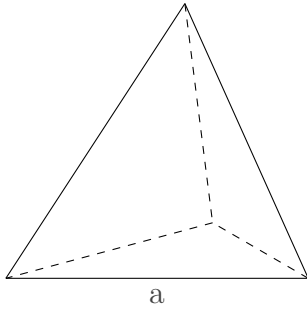

This is a regular tetrahedron. All edges are of the same length with  $a=3$  m. What is the surface area of this shape?

d)

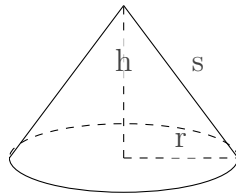

This is a cone. We have  $h=72$  m,  $s=90$  m,  $r=54$  m. What is the surface area of this shape?

4)

Calculate the approximate values of the shapes metrics a requested.

a)

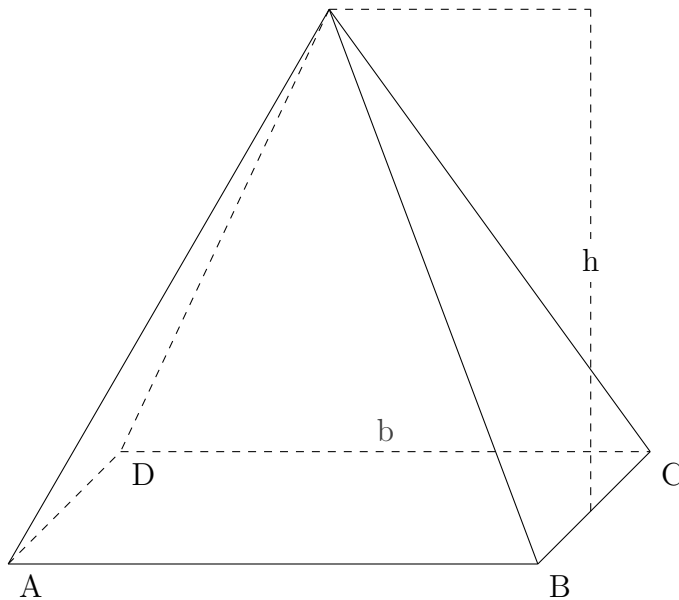

The base of this shape is formed by a square. We have  $b = 17$ ,  $h = 16$ . What is the surface area of this shape?

b)

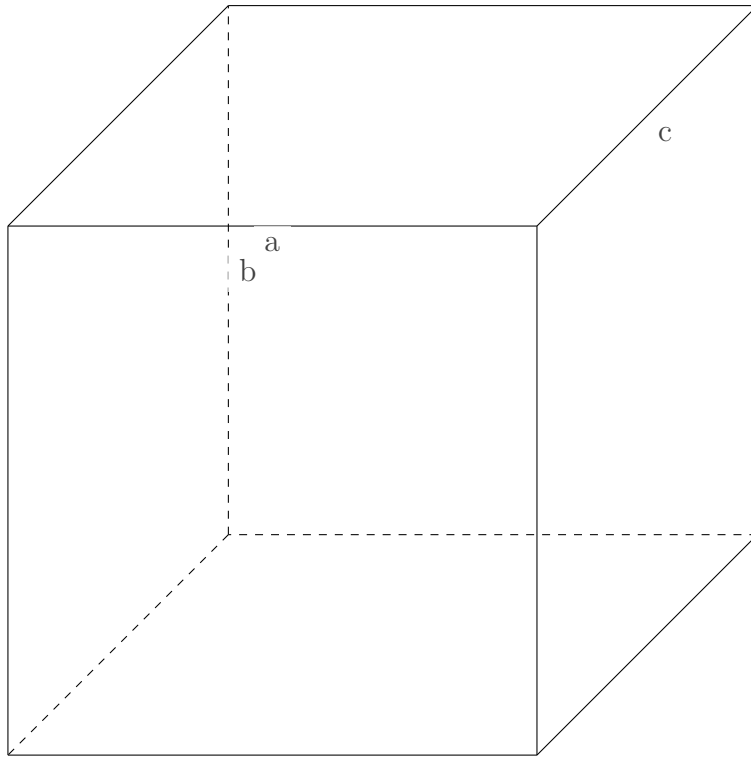

We have  $a = 12$ ,  $b = 12$ ,  $c = 10$ . What is the volume of this shape?

Good Luck!